

CLASSIC XL™



KEY BENEFITS

- Most economical flooring option
- Low initial investment
- Low annual maintenance costs
- Excellent rolling load capacity
- Durable for multi-purpose use
- Vertical and lateral shock absorption
- Many colors for activity based design
- Free floating, no adhesives or anchoring
- New or retrofit over most floors in 48-72 hours
- Unaffected by moisture or humidity
- Minimal time/cost for repair
- Portable or permanent
- Custom logos, lining, and graphics
- 12 yr. Warranty
- Made in U.S.A.

☎ **800.664.DUNK**
(3865)

▶ **SNAPSPORTS.COM**

APPLICATIONS

- Schools
- Church Family Life Centers
- Multi-Activity Centers
- Detention and Correctional Facilities
- Rehab Clinics and Hospitals
- Youth Centers
- Military
- Sports Training Facilities
- Private Athletic Clubs for:
 - Basketball
 - Volleyball
 - Futsal
 - Team Handball
 - Raquetball & Squash
 - Badminton
 - Street, Deck, & Inline Hockey
- Aerobics
- Dance
- Pilates
- Yoga
- Martial Arts
- Display
- Events and Promotions
- Home Gyms



60' x 90' Indoor Gym

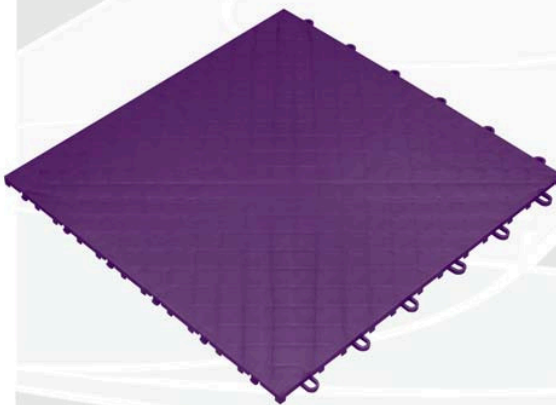

Multi-Patents Pending

CLASSIC XL SPECS

Solid Top Design (18"x18"x1/2")
 High Impact Copolymer Suspended Court Surfacing
 144 Individual Impact Zones
 Weight: 40 oz. (1133.98g)

TECHNICAL SPECS

Friction (ASTM C 1028): Dry-0.77, Wet-0.54
 Rolling Load (DIN 18032-02): Pass
 Force Reduction (DIN 18032-02):22
 Standard Deformation (DIN 18032-02):0.9mm
 Ball Rebound (DIN 18032-02): 98%
 Load Bearing Capacity (DIN 18032-02): >250 PSI
 Flatness: 0.0mm
 Lateral Movement: 0.00"-0.045"

SYSTEM LAYERS

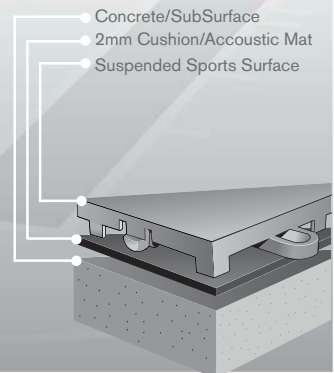

56' x 100' Indoor Gym Floor



90' x 100' Indoor Gym Floor